



**DL Roof Sheet Supplies Ltd.**

**Ordering and Installation Tips**

Steel Roof Sheets come in a variety of profiles: numerous Box Profiles, Round Corrugated, Tile Form and one-piece Insulated Panels.

Which profile you use depends on the intended purpose of the sheets, your budget and the overall look you are hoping to achieve. The majority of steel roof sheets available today are trapezoidal (box profile).

The shape has several advantages: The profile depth is generally deeper than that of round corrugated sheets, so it is stronger. Due to the straight-line construction, it tends to lap more effectively on the side laps. It can be fixed through the trough of the profile and no crushing of the profile occurs, unlike round corrugated sheets which are fixed on the crown of the profile. It can be used down to pitches as low as 4 degrees.

The majority of our profiled sheeting can be supplied in 0.5mm and 0.7mm. It is recommended that a 0.7mm thickness is used for longer sheets for greater strength and spanning ability.

## Coatings

- **Plastic Coated (Plastisol)**

This is the most popular coating of profiled roof sheets being that it is the most robust, as well as being economical. Galvanised steel profiled sheet with primer on both sides and embossed PVC on the weather-side.

Plastic Coated Roof Sheets are suitable for both roof and wall cladding systems, in both corrugated and box (trapezoidal) profile, in 0.5mm and 0.7mm thicknesses. It has a 200 micron durable, abrasion-resistant topcoat. It is available in a selection of the most popular colours. It is tested to perform well up to 25 years to first maintenance with a life of excess of 40 years in normal environments.

After approximately 10 years, delamination is likely to occur on any exposed edges. These should be pre-painted before installation to increase the longevity and it is advisable to conduct an inspection every 5 years to assess if further maintenance is required.

Specification sheets, metal samples, colour cards and technical advice available on request.

- **Paint Coated (Polyester)**

This is the same galvanised sheet underneath as the Plastic Coated sheet and the same primer specification, but instead of having the plastic coating, it has a 20 micron coating of silicone polyester paint.

This is a fairly popular option, as it saves having to paint a galvanised sheet. It is generally available in four colours: Dark Green, Van Dyke Brown, Slate Blue and Goosewing Grey (primer).

Please be aware that due to the thinner coating, this option is very susceptible to scratches. The sheeting is most vulnerable to this problem during installation so care must be taken.

**(Please note: If fixing steel sheeting directly to tanalised timber purlins it is recommended to apply a barrier tape to the top surface of your timbers to reduce contact with the primer coating. The chemicals involved in the tanalising process could possibly damage the paint finish.)**

## **To Your Specification**

All of our steel sheeting products are made to order. While this has a typical lead time of a few weeks, it has the advantage in that sheets are tailored to your individual needs.

Choose your sheet thickness, coating, profile, sheet length, and colour.

You pay for what you need. Nothing more!

## Profiles

These are our standard profiles. Other profiles are available so please refer to the "Profile Identification" section or get in contact with us if the profile you require is not listed.

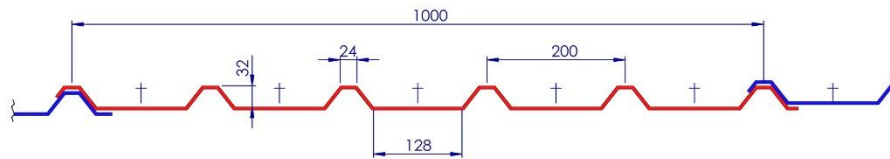

GL32

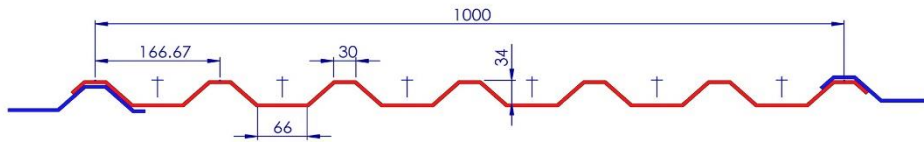

CC1000/34

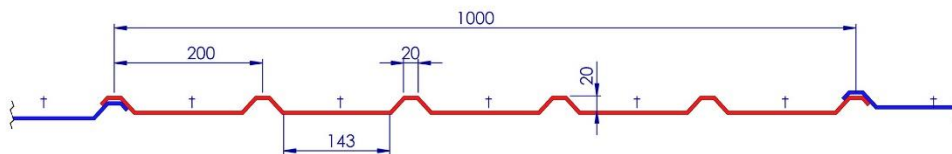
1000/20  
LINER

ALL OF THE ABOVE AVAILABLE IN REVERSE PROFILE

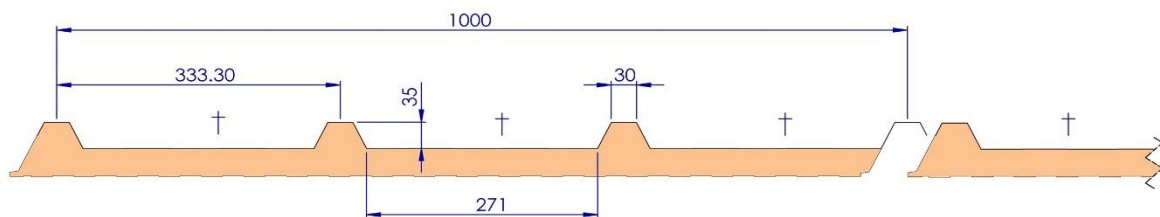

KS1000RW COMPOSITE

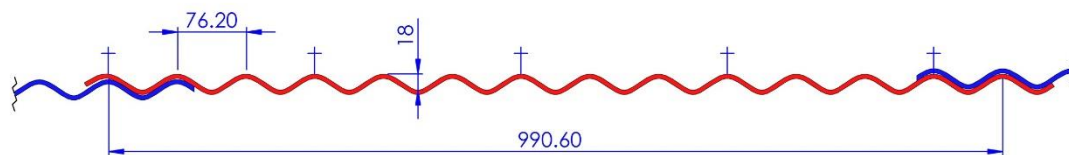

13.5/3

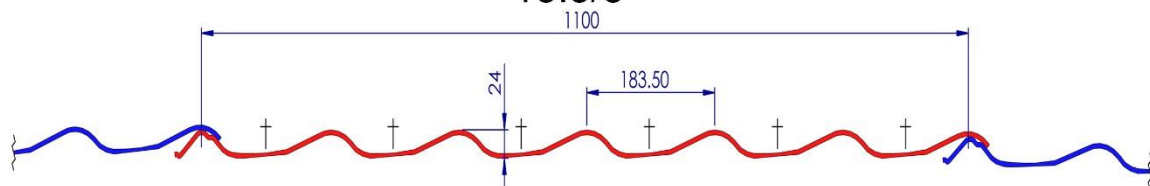

TILEFORM

## Profile Identification

If your aim is to repair or extend an existing roof and side/end lapping to existing sheeting is required, then you will need to identify your profile.

There are over 600 different types of box profile, with some of them varying drastically in appearance and others varying by only a few millimetres. Accuracy is critical when identifying profiles, if a dimension measures 17mm on a tape measure then record 17mm! Do not round numbers up or down and assure dimensions are recorded in metric.

The following diagrams illustrate the data required to identify a profile. **ALL of these dimensions are required for an accurate identification.**

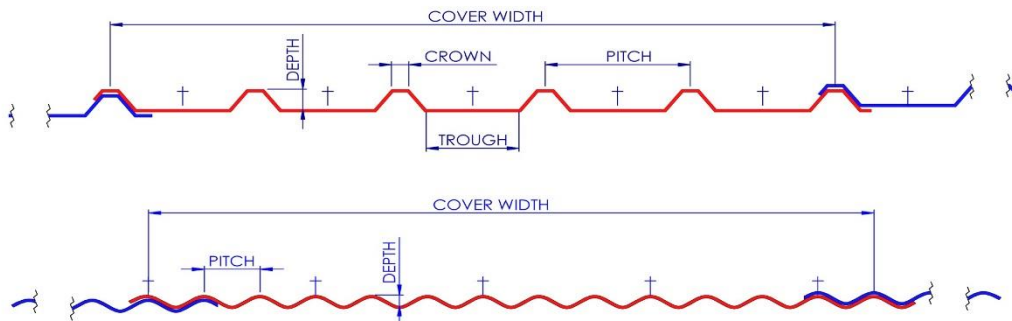

For a more positive identification of any particular profile, a rubbing should be taken of one full pitch plus a measurement of the cover width. You can send them to us or bring them in, so that we can identify the profile for you.

To take a rubbing, firmly hold a piece of paper against the corrugated edge of the roof sheet and rub with a soft crayon or dirty thumb to highlight the shape of the profile. Alternatively, use the corrugated edge of the sheet and with a pencil, trace the line of the profile making sure you mark the full width of the sheet.

## Colours

The following are our standard colours. Other colours are available but sometimes incur extra cost (depending on their current availability).

Please enquire if you require a colour not listed.

### PLASTISOL



OLIVE GREEN



JUNIPER GREEN



VAN DYKE BROWN



GOOSEWING GREY



MERLIN GREY



SLATE BLUE

### POLYESTER



JUNIPER GREEN



VAN DYKE BROWN



GOOSEWING GREY



SLATE BLUE

## Delivery

We offer a delivery service for the South West. Currently our delivery vehicle is a Mercedes Sprinter van with a 4.9m bed so the longest sheets we can transport is 6400mm. For longer sheets it is possible to offer a direct delivery to site from the manufacturer but this will usually incur extra charges.

Please ensure that for all deliveries, there is sufficient site access and offloading facilities.

It will be required that the customer or representative is present during delivery - to receive materials, sign paperwork, and to help the driver unload goods (if a forklift is not present.)

## Collection

If collecting, it is the customers' responsibility to ensure that the vehicle carrying the goods is suitable in terms of weight and length carrying capacity.

DL Group and its employees retain the right to refuse to load an unsuitable vehicle if he/she thinks it will be unsafe to do so.

## Fixing

- **Box Profile and Tileform**

When fixing Box Profile or Tileform sheeting it is important that you make sure that you fix through the valley of the profile. Fixing through the valley will assure a strong fixing point and due to the flat profile and galvanised bonded washers of the fixing screws it will not leak.

A common mistake is to fix through the crown of the profile, while this method is correct for traditional round sheeting, with Box Profile and Tileform sheets, fixing this way you are more likely to get leaks due to profile distortion.

On side laps it is recommended to run lalseal tape the entire length of the sheet and use stitcher screws at least once every 500mm.

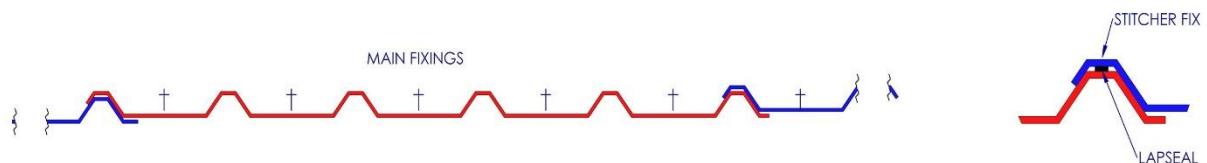

If your roof slope is to be made up of two or more sheets then extra consideration should be allowed at the end lap detail.

Typically two continuous runs of lapseal tape should be used. The lower strip is the primary weather seal, this should be positioned as close as possible to edge of the top sheet. The other strip of lapseal is a secondary defence to prevent moisture entering the overlap from inside the cavity. Once again, stitcher screws should then be employed, preferably every profile, but every other profile should suffice.

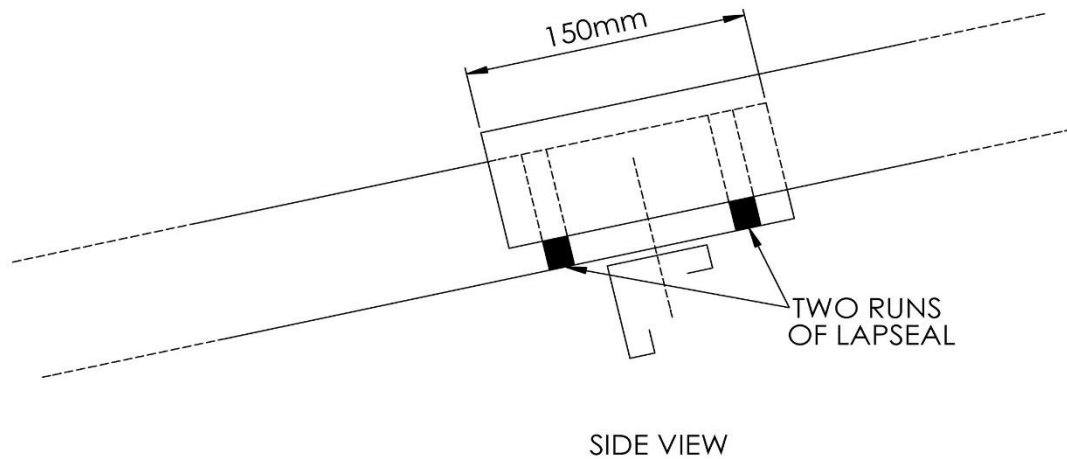

- **Round Corrugated**

For Round Corrugated sheeting follow the same recommendations listed under “Box Profile and Tileform”, the only difference being that you always fix through the crown of the profile.

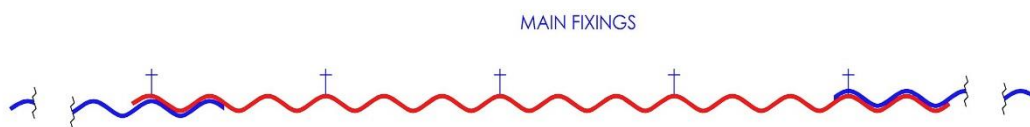

## Purlin Spacing

Steel roof sheets are always fixed through horizontal timber or steel purlins. Ideally purlin spacings should not exceed 1200mm for box or 3” profile and 600mm for Tileform.

Sheets should be fixed through every available purlin (assuming purlins @ 1200mm centres) with a minimum of three fixings per purlin across an individual sheet.



## Flashings

We offer a bespoke flashing service, cut and folded to your requested wing dimensions and angles. Standard lengths are 3000mm long but we can provide you with a shorter length, if required.

- **Ridge Flashings**

Available for apex, or mono sloped roofs. In order to price effectively we will need to know the wing dimensions and angle required.

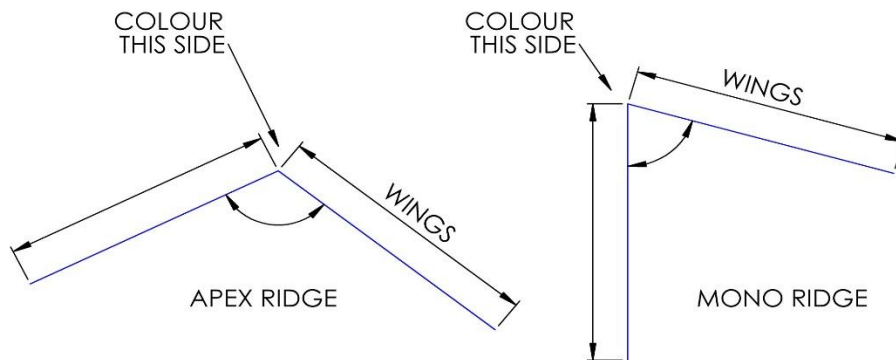

- **Top Apron Flashings**

To be used on roofs that abut onto a wall at the highest point. Much easier to dress lead over a flat winged flashing, as opposed to a profiled sheet.

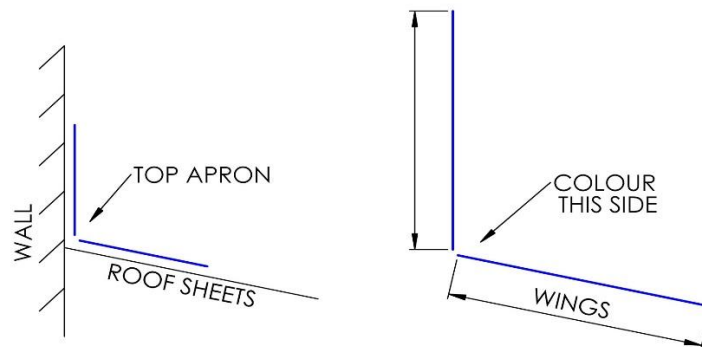

- **Barge Flashings**

Also known as a verge flashing, they are used to tidy the exposed edges of roofs. Barge flashings are always 90°, but wing dimensions will vary depending on your requirements. We highly recommend that barge flashings are measured/ordered after your roof sheets have been installed. It cannot be guaranteed that pre-made barge flashings will terminate on the preferred roof profile.



ILLUSTRATION SHOWS BARGE FIXING THROUGH THE FIRST CORRUGATION, HOWEVER IT IS QUITE ACCEPTABLE TO FIX THROUGH THE SECOND IF YOU WISH.

- **Side Apron Flashings**

Same principles as a barge flashing, but used where the side of a roof abuts a wall. As with barge flashings, we highly recommend side apron flashings are measured/ordered after your roof has been installed.

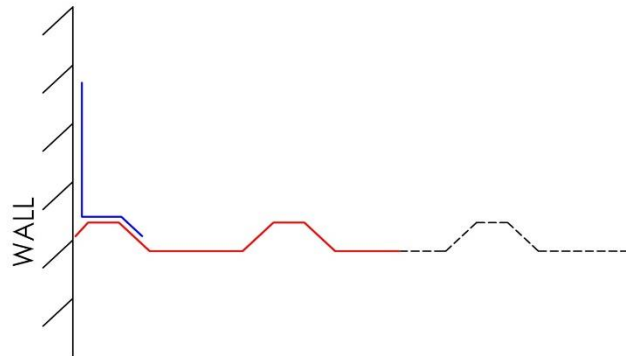

We can also offer flashings for drips, eaves, bridging, etc. All follow the same principles as the above examples for accurate pricing and manufacture.

**PLEASE NOTE: Unless specific wing dimensions are requested, we will price flashings in an approximate size, these may not meet your actual requirements. Please specify before ordering!**

## GRP Rooflights

GRP (Glass Reinforced Polyester) Roof lights are available for most steel options with the exception of Tileform sheeting.

Also available in a variety of weights and fire ratings. For single skin use we would recommend a Class 1 Fire Rating (SAA1) with a weight of 3kg/m<sup>2</sup> ideally, although Class 3 (SAB3) sheets are more commonly used due to their availability and reduced price.

It should be noted that to comply with current building regulations a Class 1, 3kg/m<sup>2</sup> Roof light should be used.

## Composite Insulated Panels

Using Composite Insulated Panels can accommodate the most creative and stylish visions as well as meeting demanding regulations and specifications, for any roof or wall assembly applications.

The Composite Insulated Roof Panel system offers a viable alternative to built-up and boarded systems as it is a one-fix system, lightweight and simple to install which ultimately reduces labour costs.

The outer skin has a thickness of 0.5mm and the inner white enamel skin 0.4mm. The panel coatings can come in a plastic coated finish in various standard colours like Van Dyke Brown, Olive Green and Merlin Grey - or with metallic finishes which can satisfy the most creative specification desires.

When used in roof applications, construction can be safely undertaken down to a 4 degree pitch using conventional through fasteners.

Factory assembled roof lights and flashing accessories complete the system offering cost effective, fully insulated 'warm construction' for industrial and commercial buildings and low air leakage performance, offering long term lifecycle durability.

When ordering composite panels there are three criteria unique to this product that will need to be considered.

- **Insulation Thickness**

The insulation core is available from 40mm – 150mm. If it is to meet Building Regulations, then the current minimum is 115mm (for a roof) and 80mm (for side cladding). The insulation thickness is measured from the inner liner to the bottom of the roof/wall profile.

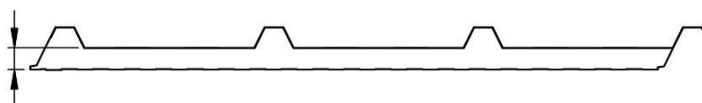

- **Cutback**

During the manufacturing process, the bottom liner and insulation core are made shorter than the top sheet. How much shorter is the decision of the customer. Cutbacks are necessary to allow the top sheet to run into a gutter or to enable end lapping.

For end lap cutbacks, it is recommended that a minimum cutback of 150mm is used.

There must always be a cutback and the minimum size available is 20mm.

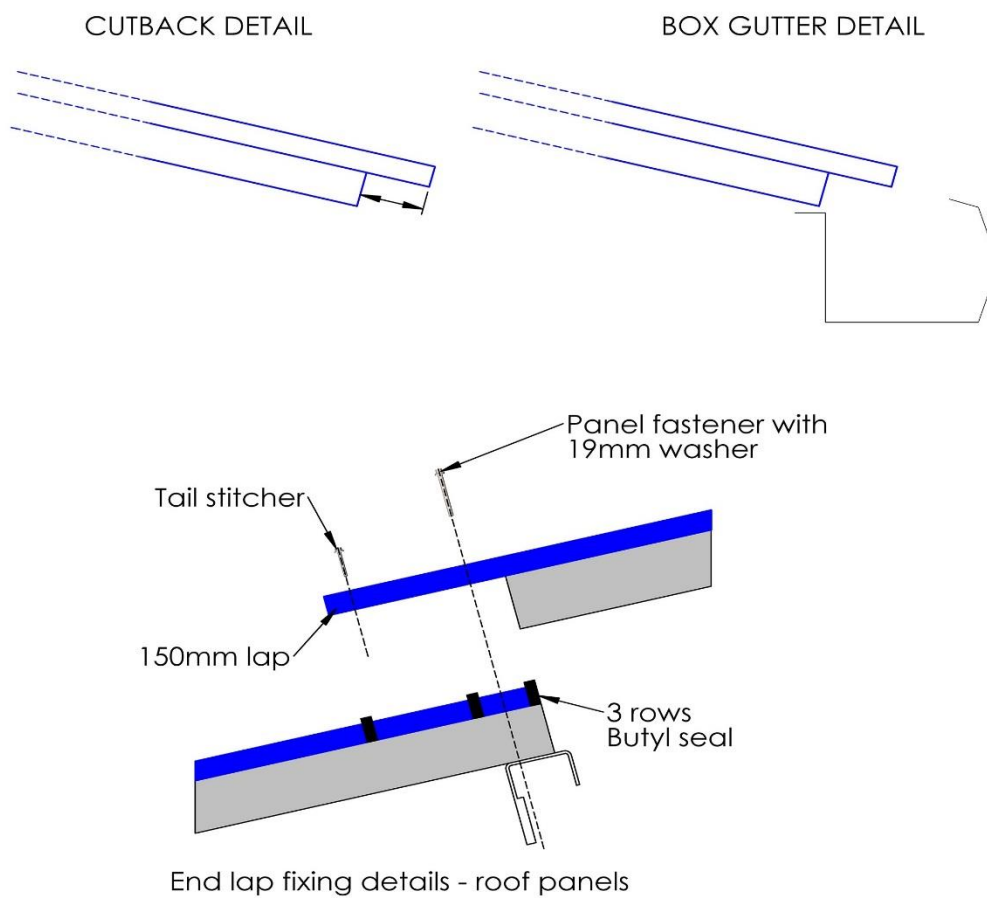

- **Handing**

Similar to the cutback; during manufacture, one of the side profiles is left without any insulation core beneath it. This is to enable side lapping. Which side of the profile is the customer's decision and usually based on the sites prevailing wind direction.

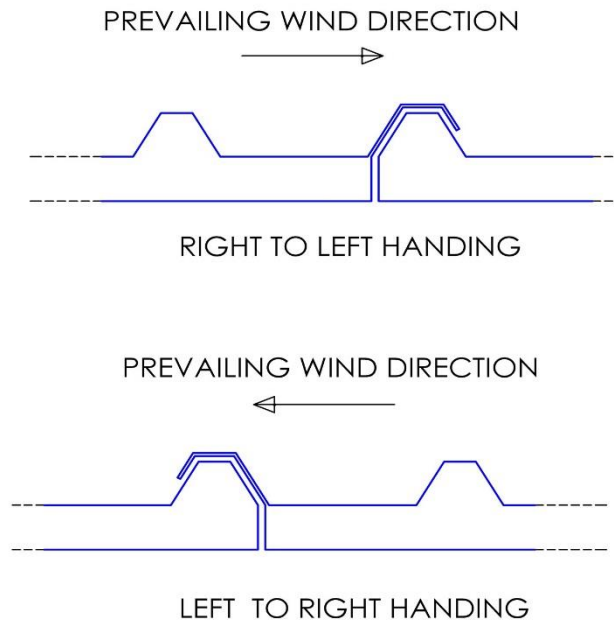

## ECO Panel

Eco Panel is a lightweight insulated panel very similar to the standard composite sheeting but the steel liner has been replaced with an aluminium foil.

Reduced weight and price with the benefits of a composite panel.

Eco Panel is available in 30mm, 40mm, 60mm and 100mm insulation core thicknesses, in lengths between 2500mm and 13,600mm.

Like standard composite, Eco Panel is manufactured with cutbacks and handings to your specification.

## Box Gutters

On roofs with longer rafter lengths, conventional plastic guttering does not have the capacity required to take the extra volume of water. In cases such as this, the best option is a made to order box gutter. Manufactured to your specification and available with stopends and outlets.

At the ordering stage it will need to be ascertained what wing dimensions and angles you will require for your gutter.

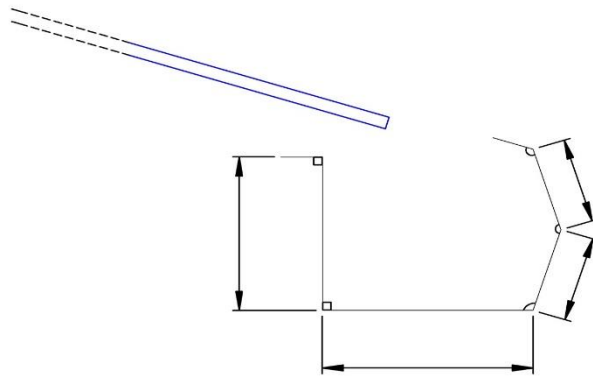

Box Gutters are available in 3000mm lengths as standard and joined with the use of an internal Butt Strap. The Box Gutter lengths are butted up against each other and the strap fixes to the inside, joining the two gutter sections together.

Ensure 50mm wide Lapseal Tape is used the full girth on both edges of the strap and stitcher fix from the outside of the gutter. These fixing methods should also be employed when installing the stopends and outlets.

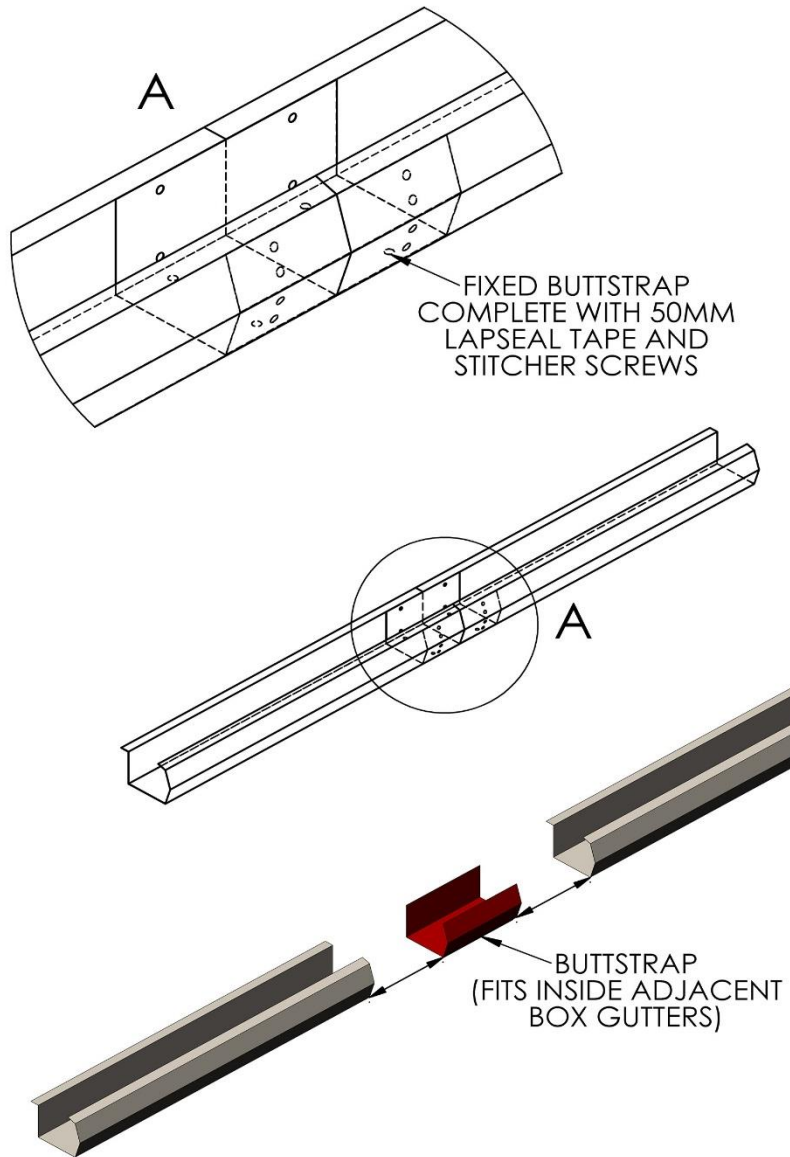

To ensure strength and rigidity, saddle brackets should be stitcher fixed from the front wing of the Box Gutter to the top, or bottom of the roof sheet. Saddle Brackets are supplied in 3000mm lengths and cut down into 600mm lengths (typically) on site. Bracket spacing should not exceed 1000mm.

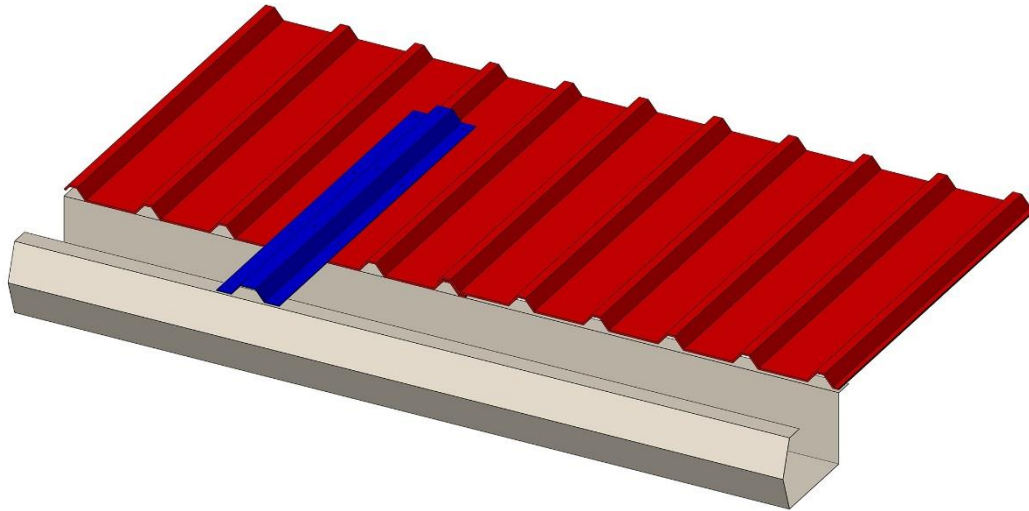



## Liner Panels

Liner panels are used on the inside of buildings, usually as part of a Built-Up System. Constructed from 0.4mm thick galvanised steel - with a white polyester finish on the outer face and a grey alkyd primer finish on the reverse.

Due to the reduced thickness of liner panels it is recommended that sheet sizes do not exceed 4000mm. This is to reduce the risk of kinking these thin sheets during handling and installation.

At the ordering stage, it will need to be specified whether sheets are to be fixed “Over Purlin” or “Under Purlin”.

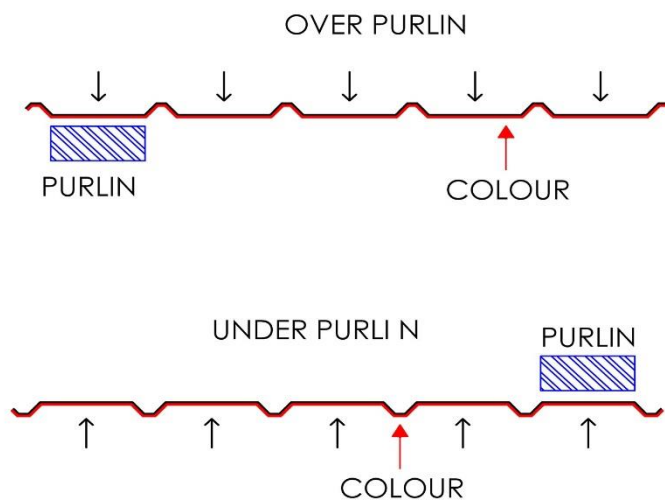

## Condensation and Built-Up Systems

Steel sheeting, being a conductor of heat (in extreme conditions), will likely suffer from condensation issues unless precautions are taken.

Here are a few solutions:

- **Anti-Condensation Coating**

All of our steel sheeting can be manufactured with a fibre microsphere structure covering the primer side of the sheet which is able to absorb up to one litre of moisture per square metre.

To assure that the coating performs correctly, foam fillers should not be used. This helps to increase air flow. Also, the coating should be varnished at the eaves and end laps to prevent water ingress.

Anti-Con coating is only available with plastisol coatings on sheets that are 0.7mm thickness.

- **OSB Boarding**

A very effective method of reducing condensation is to clad your roof timbers with OSB Board. Boards must be joined over a supporting timber and foil tape must be applied over the join. Then, simply fix your sheeting down through the OSB and into the supporting purlins.

- **Overclad**

Why not reduce labour and disposal charges and use your old roof to reduce potential condensation problems?

Either fix timbers or a Tech Bar System to your existing roof, and then fix the new sheeting on top. You can even add loft roll insulation or Celotex boards to increase your building's thermal efficiency.

This option is particularly popular for customers with asbestos roofs.

- **Built-Up Systems**

Short of using a one piece composite panel, a Built-Up System is the professional's choice for eliminating condensation:

0.4mm Liner panels are fixed to an existing purlin structure. Next, a Techbar system is utilised with either loft roll insulation or Celotex board placed in between the bars. Finally, the sheeting is fixed to the Techbar with Light Section fixings.